

VE-13 / VE-12 / VE-11-V / VE-11-H Velocity Sensor

Features

- Wide Full Scale Range, ± 1 to ± 100 mm/s
- Bandwidth 1 Hz to 315 Hz
- Civil Engineering and general vibration measurement applications
- Built-in Impulse Test Circuit
- Single Bolt Mounted Housing provides up to $\pm 10^\circ$ of Levelling Adjustment



Outline

The VE Velocity Sensors are engineered for consistent performance over a long lifetime. Advanced computerised testing, manufacturing techniques and quality control are used in the production process to provide both, the uniform parameters and the rugged qualities required in modern velocity sensors.

With the new VE-1x, 1 Hz Velocity Sensor now it is possible to measure vibrations in accordance with DIN 45669-1.

The sensor module has proven itself successfully worldwide for many years in different applications. The symmetrical rotating dual coil construction minimises the force on the spring arms. The use of precious metals ensure optimum electrical contact and a long operating life.

The VE Velocity Sensors operate from a wide range of input voltages and can be used for a variety of civil engineering and general vibration measurement applications. The VE-11-H is uniaxial horizontal, the VE-11-V uniaxial vertical, VE-12 biaxial and the VE-13 is a triaxial velocity sensor.

The VE Velocity Sensors are housed in a very compact 195 x 112 x 96 mm case. The sealed cast aluminium housing contains a MS style connector or a sealed cable inlet. The housing also incorporates a single bolt mount with three levelling screws, which offers extended adjusting capability during mounting.



Specifications VE-13 / VE-12 / VE-11-V / VE-11-H Velocity Sensor

General Characteristics

Application: Civil engineering, general vibration measurement

Configurations:

	Triaxial	Biaxial	Uniaxial	Axes	Alignment**
VE-13:	■			X – Y – Z	H – H – V
VE-12-H:		■		X – Y	H – H
VE-12-V:		■		X (or Y) – Z	H – V
VE-11-H:			■	X (or Y)	H
VE-11-V:			■	Z	V

** H: Horizontal, V: Vertical

Full Scale Range: ± 100 mm/s
optional: $\pm 1, \pm 10$ mm/s

Specification

Instrument Type: Digital grade long travel geo-phones
Dynamic Range: > 96 dB
Linearity: < 0.3 % of full scale
Cross Axis Sensitivity: < 0.1 % of full scale
Frequency Response: 1 to 315 Hz
Damping: standard 0.7
Full Scale Output: 0 ± 10 V differential (20 Vpp)
optional 2.5 ± 2.5 V single-ended (5 Vpp)
0 to 20 mA current loop
Output Impedance: < 50 Ω
Self Test: Impulse Test
Measuring Range: See plot

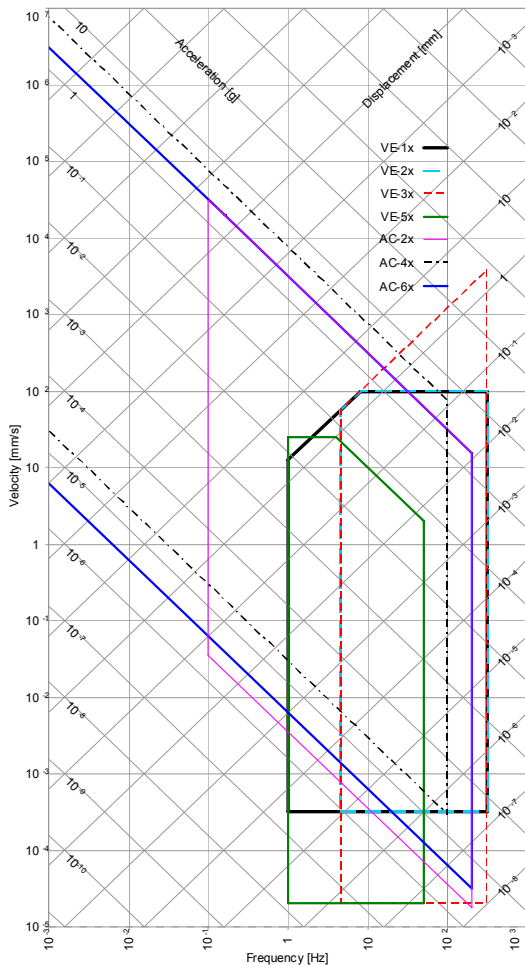

Power

Supply Voltage: 9 to 12 VDC
Supply Current: 12 mA per axis

Connector Pin Configuration

Pin 1-2, 3-4, 5-6: Signal output for axis X, Y, Z
Pin 7-8: Test input, Digital test-pulse (0 – 12 V)
Pin 9-10: +12 VDC Power Supply
Pin 11-12: Sensor Mode
Case: Shielded Ground

Environment / Housing

Housing Type: Cast aluminium
Sealed access cover
Housing Size: 195 x 112 x 96 mm
Weight: 2.0 kg
Index of Protection: IP 65
optional IP 68
Temperature Range: -25 to 85 °C (operating)
-40 to 100 °C (storage)
Humidity: 0 to 100 % (non-condensing)
Mounting: Single bolt, surface mount, adjustable within $\pm 10^\circ$

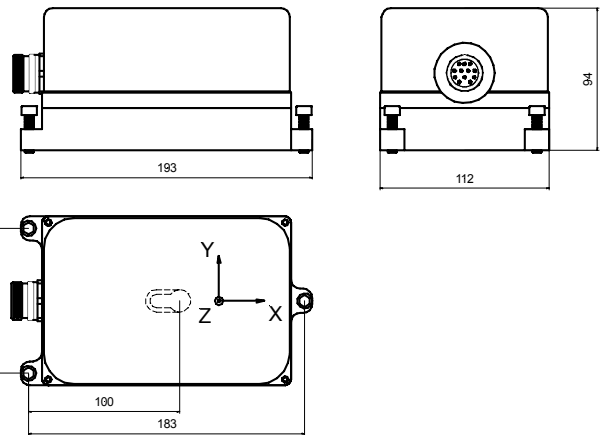

Standard VE-1x

Floor mounted, Full scale ± 100 mm/s
2 m cable with sensor mating connector,
concrete anchor and user manual on CD

Options

Cable & connector: Sealed cable inlet, replaces connector
Cable with shielded twisted pairs for any length (including mating sensor connector) with open end Cables for connection to GeoSIG recorder
Connector on user specification mounted at cable end
Housing: Watertight IP68 housing
Stainless steel protective housing
Temperature Range: -25 to 100 °C (operating)
Temperature Output: Temperature sensing at the sensor side

Ordering Information

Specify: Type of VE-1x, full scale range, and other applicable options